

MAGNEPLANAR® MC1

Instruction Manual

White Bear Lake, Minnesota

www.magnepan.com

Magneplanar MC1 Owner's Manual

- 1. INTRODUCTION..... 3
- 2. PACKAGING..... 3
- 3. INSTALLATION..... 3
 - MC1 WALL BRACKET INSTALLATION..... 3
 - MC1 INVERTED INSTALLATION..... 4
 - A. Front Channel Installation..... 4
 - B. Front Wall Installation..... 5
 - C. Dual Center Channel Installation..... 6
 - D. Rear Channel Installation..... 7
- 4. MC1 SPECIFICATIONS..... 9
- 5. MGMC1 ACCESSORY KIT..... 9

1. INTRODUCTION

Congratulations on your purchase. The Magneplanar MGMC1 loudspeaker was conceived and designed for perfectionists. One of the most revealing loudspeakers made, it will provide outstanding music and home theater reproduction when used with high quality components. Due to the elegant simplicity and ruggedness of the design, the Magneplanar MGMC1 loudspeaker will give many years of trouble-free service.

2. PACKAGING

Save all packaging. If you need to transport the speakers, they can be shipped safely only in the original packaging. You may never have to return your loudspeakers, but should the occasion arise, they should not be shipped in any packaging but the original. Should you discard it, you may purchase new packaging from the factory.

3. INSTALLATION

The MC1 is a multi-channel speaker designed for front channel, side, or rear channel applications. The MC1 has a frequency response from 80Hz to 24kHz and is intended for use with a subwoofer. Set your processor or receiver to “small speaker” for the MC1. Frequencies below 80Hz will be assigned to the subwoofer.

The MC1 is designed to be placed next to a wall or cabinet. The boundary of a wall or cabinet is calculated in the MC1 design to achieve smooth frequency response to 80Hz. If an optional speaker stand is used, the best results will be achieved by placing the MC1 as close as possible to a wall or cabinet.

In front and surround applications, the quasi ribbon tweeter should be faced towards the listener. The thin aluminum quasi ribbons can be seen through the grille cloth. In all installations, the quasi ribbon should be positioned away from the wall or cabinet, with the speaker wires next to the wall.

Connect the (+) red output from your amplifier to the red wire on the MC1, and (-) black of the amplifier to the black wire on the MC1. If the speaker wires are not routed through a wall or cabinet, “hide-a-chord” channels can be attached to the wall as shown below.

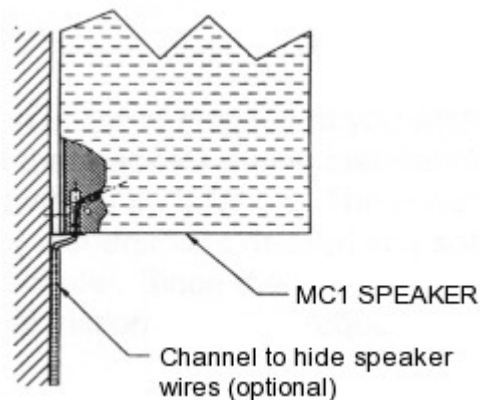

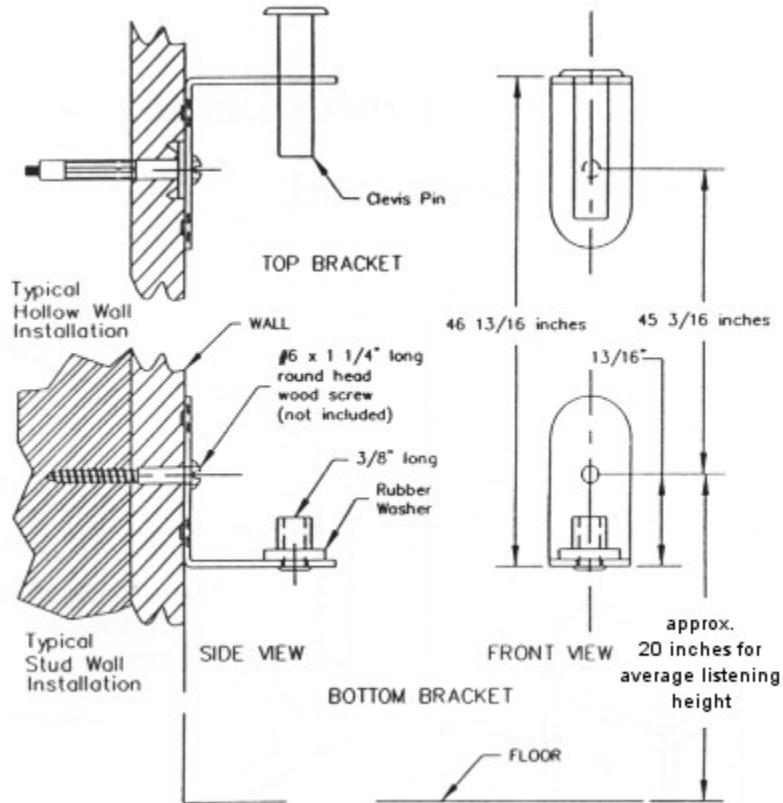

MC1 WALL BRACKET INSTALLATION

1. Locate holes on stud or use hollow wall anchors as shown.
2. Use level to check vertical alignment.
3. Drill holes-- $\frac{5}{16}$ " for hollow wall anchors or $\frac{3}{32}$ " for wood screws.
4. Fasten brackets to wall as shown.
5. Put rubber washer onto bottom bracket post.
6. Install speaker by feeding wires through hollow center of post. Pull excess wires through lower bracket and set speaker on bottom post.
7. Align hole in top of speaker with hole in top bracket and insert clevis pin.
8. If wall installation is not feasible, an optional floor stand is available.

MC1 INVERTED INSTALLATION

The MC1 may be installed in an inverted position (if you wish to have the wires exit at the top of the speaker). Invert the brackets during installation. Note that the quasi ribbon driver is lower with an inverted installation. The inverted position may be desirable where high frequency dispersion is desired in a sofa or chair which places the listener below the level of the tweeter. Since the pin may fall out in an inverted position, Magnepan will provide a special friction pin upon request.

A. Front Channel Installation

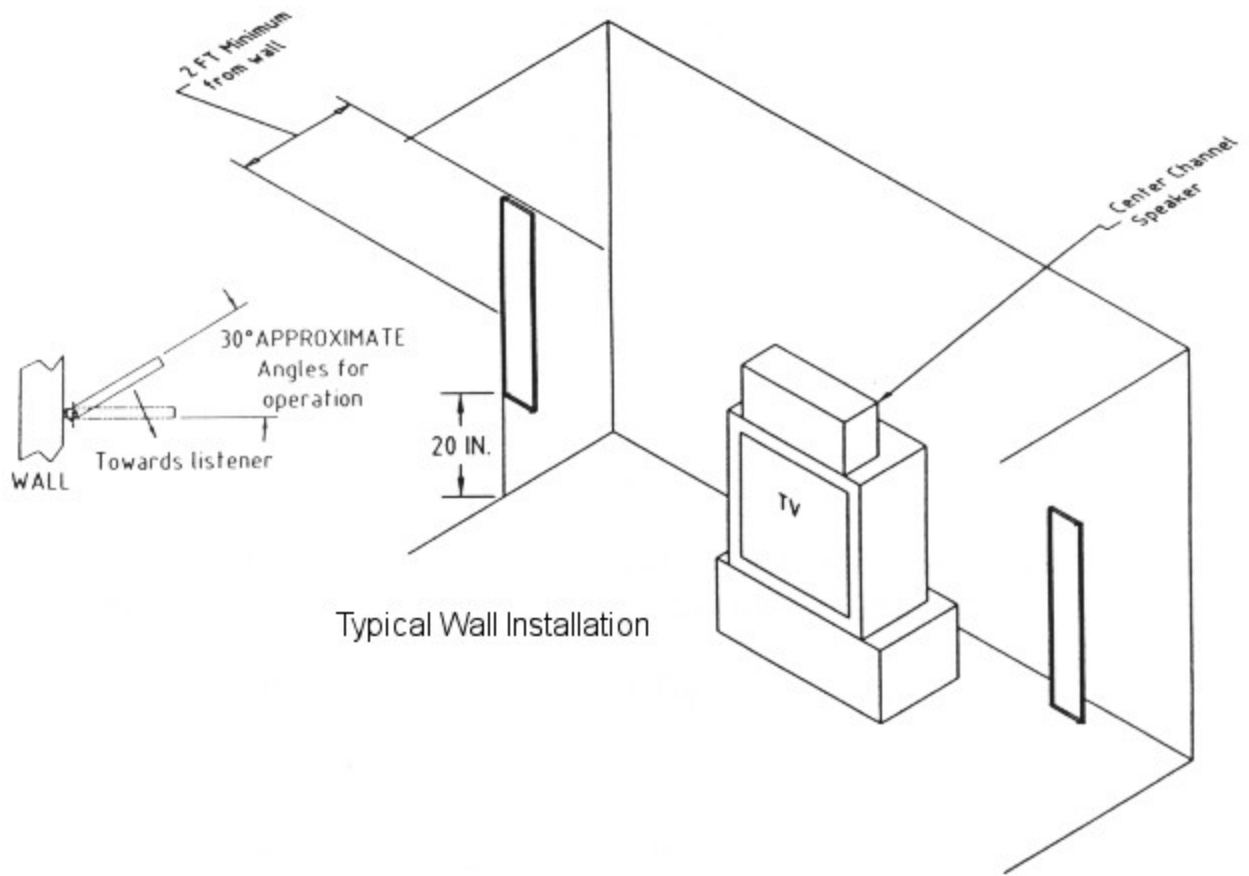

Typical Cabinet Installation

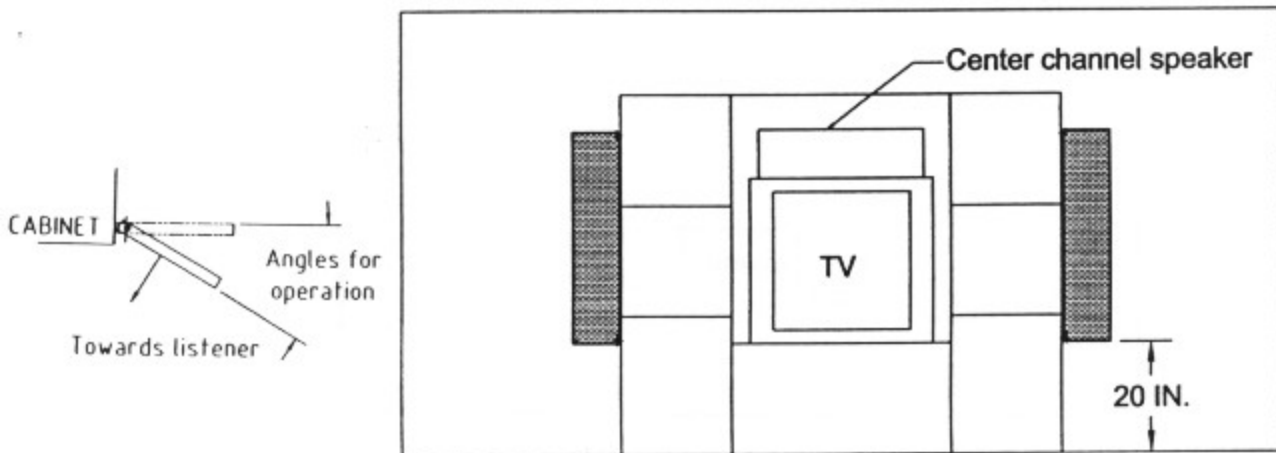

The MC1 may be placed flat against the wall or cabinet when not in operation. In operation, the speaker should be positioned as shown above.

B. Front Wall Installation

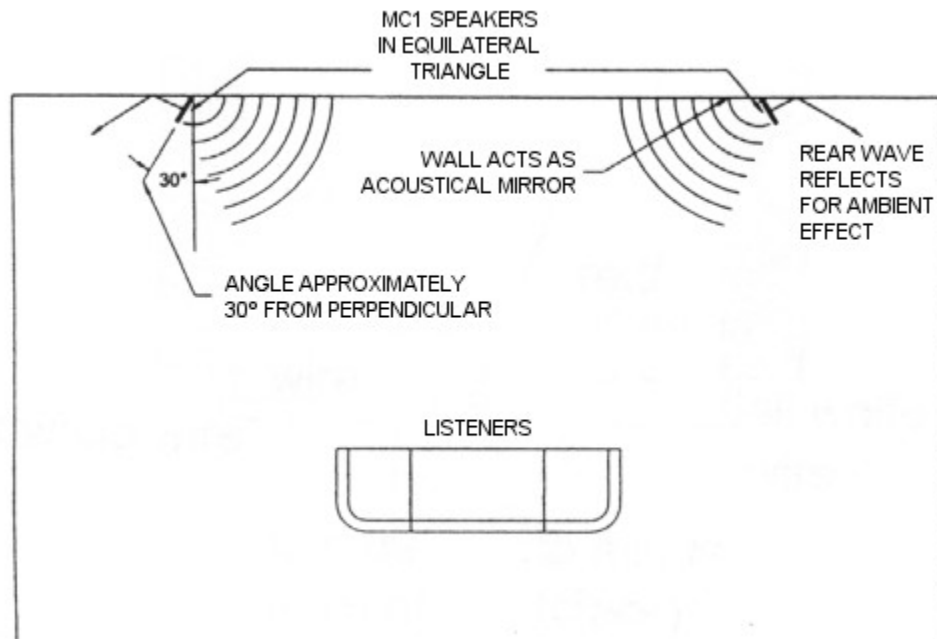

An installation on the front wall as shown above is best achieved with a rather wide placement (approaching an equilateral triangle with the listener).

C. Dual Center Channel Installation

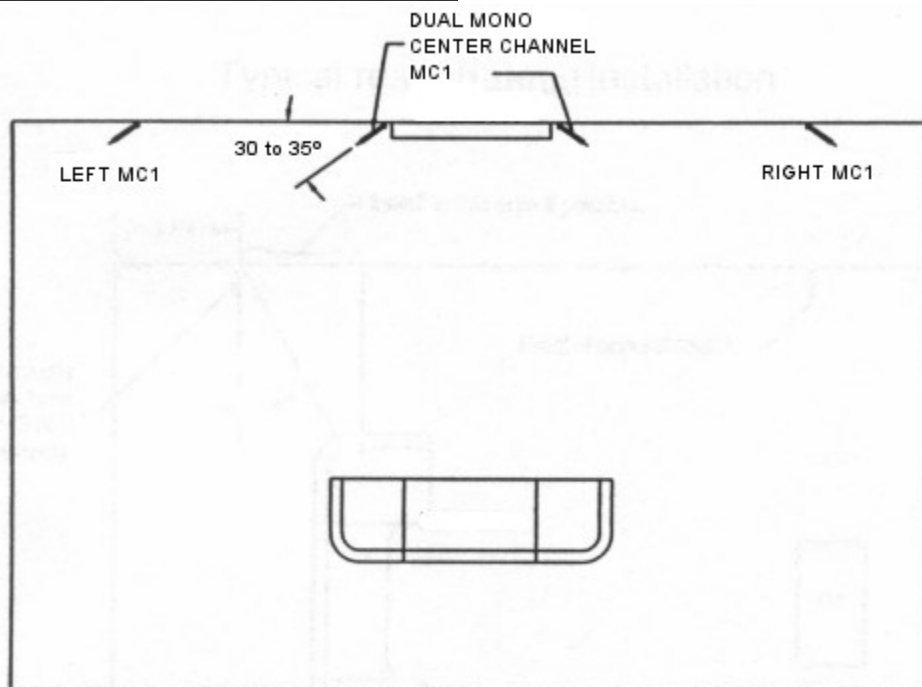

A dual mono center channel MC1 achieves a derived center channel image. When sitting to the right, the left center channel speaker that is on axis with the listener is louder than the right center channel speaker, thereby keeping the center channel image in the middle of the screen.

For this type of installation, hook the 2 center channel MC1s in series as shown below.

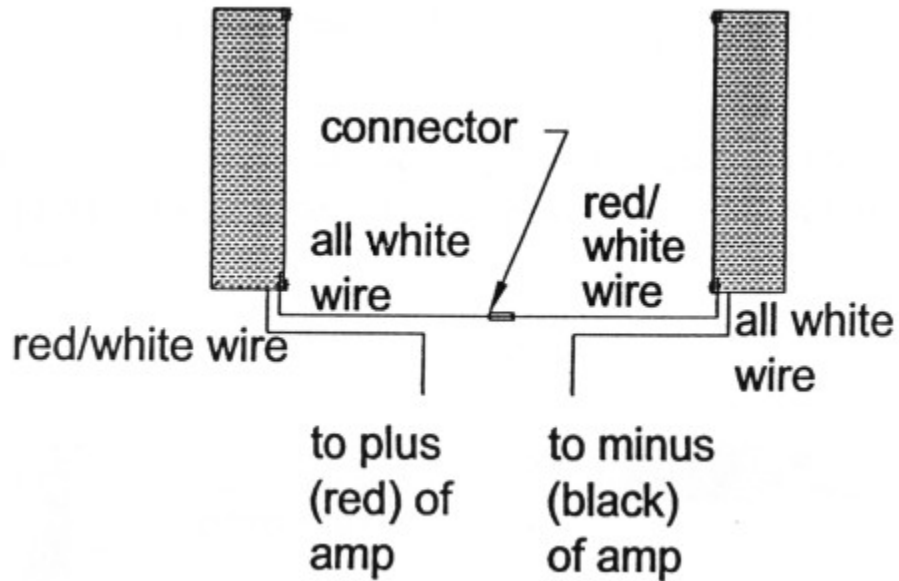

If possible, use a separate amplifier on each MC1 in a dual center channel configuration. Magnepan does not recommend hooking dual center channel MC1s in parallel (to be operated by one center channel amplifier).

D. Rear Channel Installation

Typical rear channel installation

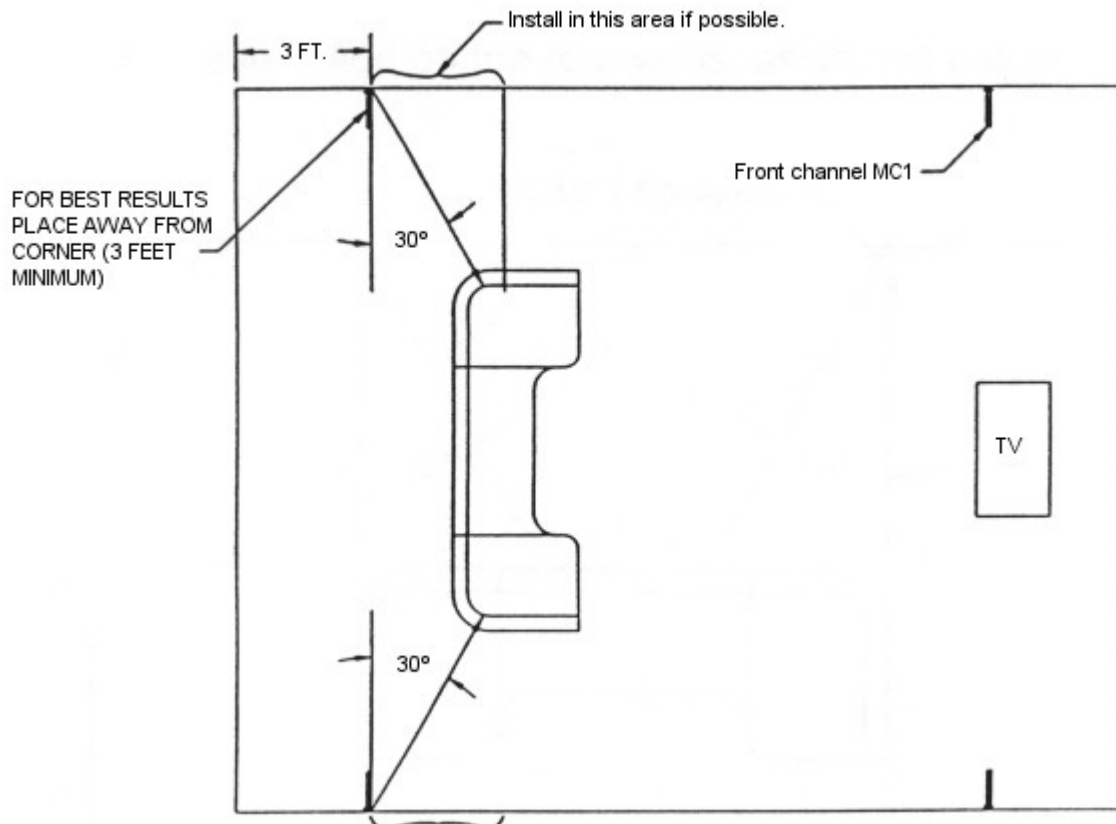

More precise rear imaging can be achieved by increasing the angle and receiving more direct radiation from the speaker. However, our experience is that a direct radiating surround speaker can be too precise in rear imaging, and the listener becomes aware of the sound coming from a speaker which ruins the holographic effect of surround sound.

Ideally, the MC1 should be positioned about 20 inches from the floor, but may be installed as high as the ceiling as shown below. It also shows an optional horizontal ceiling installation.

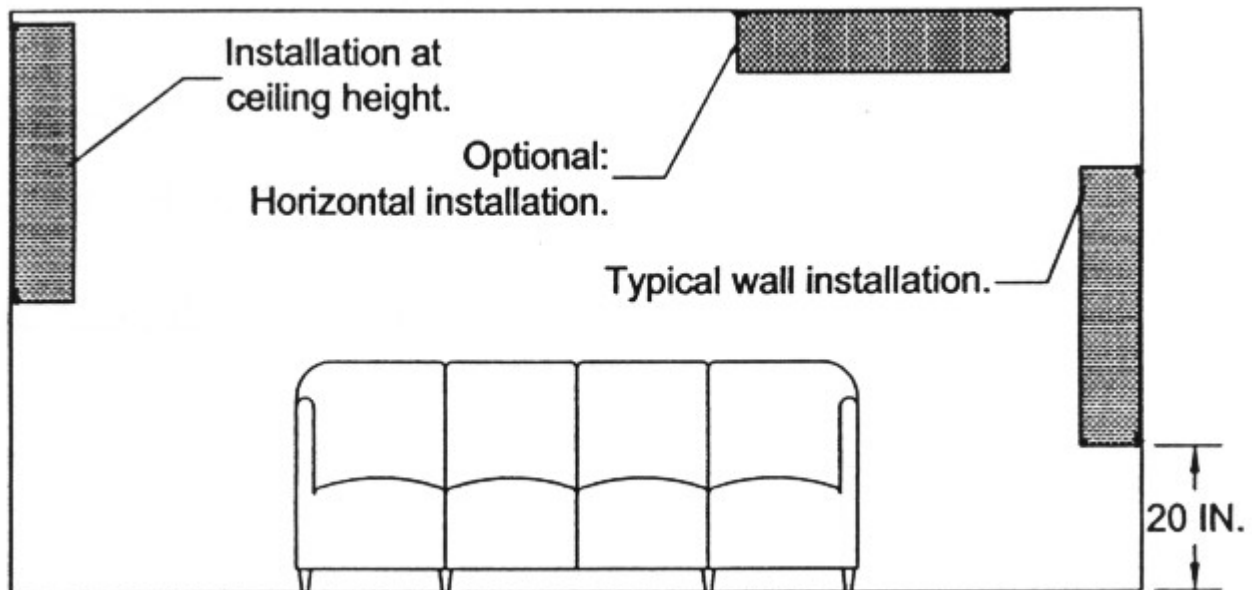

The MC1 may also be installed on the rear walls, as shown below.

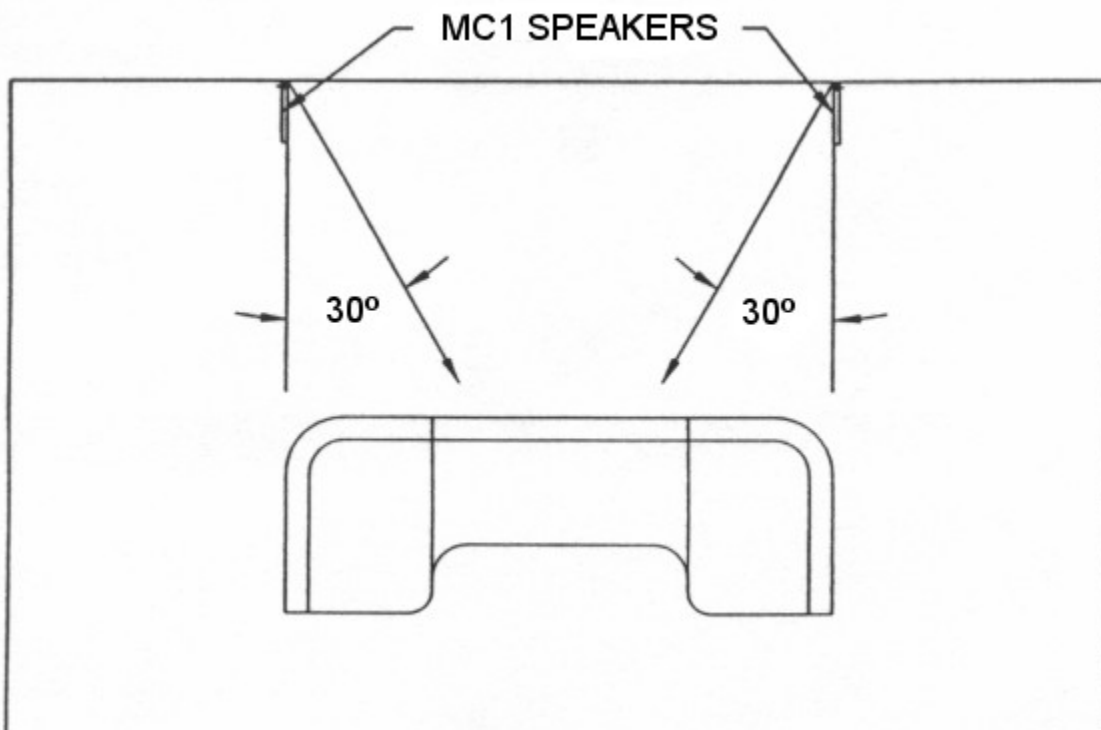

4. MC1 SPECIFICATIONS

System Description: 2-Way Quasi Ribbon/Planar-Magnetic
Frequency Response: 80Hz to 24kHz +/- 3dB
Recommended Power: 40 to 200W @8 Ohms. For further information, see FAQ on web site at <http://www.magnepan.com/faq.php#power>
Sensitivity: 88dB/500Hz/2.83V
Impedance: 4 Ohms
Dimensions: 38-1/4" H X 10-1/4" W X 1" D
Shipping Weight: 28 lbs./pair

5. MGMC1 ACCESSORY KIT

2 TOP WALL BRACKETS
2 TOP WALL BRACKET PINS
2 BOTTOM WALL BRACKETS
4 WALL FASTENERS
2 RUBBER WASHERS
1 OWNERS MANUAL
1 THANK YOU LETTER