

MAGNEPLANAR® MG12/QR

Instruction Manual

MAGNEPLANAR® PRODUCTS

WHITE BEAR LAKE, MINNESOTA 55110

www.magnepan.com

1. INTRODUCTION

Congratulations on your purchase. The Magneplanar MG12/QR loudspeaker was conceived and designed for perfectionists. One of the most revealing loudspeakers made, it will provide outstanding music reproduction when used with high quality components. Due to the elegant simplicity and ruggedness of the design, the Magneplanar MG12/QR loudspeaker will give many years of trouble-free service.

2. GENERAL DESCRIPTION

The MG12/QR consists of a 2-way planar magnetic driver utilizing a common ½ mil. Mylar diaphragm. The voice grid of the bass section consists of a lightweight aluminum wire. The Quasi Ribbon Tweeter is made of 1 mil. aluminum foil.

3. PACKAGING

Save all packaging. If you need to transport the speakers, they can be shipped safely only in the original packaging. You may never have to return your loudspeakers, but should the occasion arise, they should not be shipped in any packaging but the original. Should you discard it, packaging is available.

4. ASSEMBLY

The four support feet for the MG12 are shipped in the speaker carton along with the 8 mounting bolts. Install the foot supports on the back of the speakers and tighten the bolts.

5. HOOKUP

The MG12 features unique, high current connectors which provide optimum contact area with speaker cables up to 10 gauge.

Simply strip 1/2" of insulation from the end of the cable. Insert the cable into the top set of connectors and tighten the set screws with the Allen wrench provided. Banana plug connectors can be used and locked in place with the set screws. Spade lug adapters are available from your Magneplanar dealer for speaker cables that are incompatible with the Magneplanar high current connector.

To ensure proper phasing of the speakers, make sure the plus (red) is to plus and minus (black) is to minus.

6. CAUTION--CAUTION--CAUTION

A) The terminal plate states a maximum fuse value of 4 amps Type 3AG (“normal” or fast blow”) We recommend that 4 amp fuses continue to be used. The bass section does not require fusing protection. This fuse value should never be increased or bypassed. Do not use slow-blow fuses. If these precautions are taken, our destruct tests show that it is impossible to burn out these drivers. **BURNED OUT TWEETERS ARE NOT COVERED UNDER THE WARRANTY.**

B) For owners of cats, we recommend cat repellent around the base of the speakers.

7. SPEAKER PLACEMENT

Proper speaker placement and room acoustics can have more effect on a music system than upgrading one of the components in the system. Unfortunately, there is no definitive guideline which will cover all possible listening rooms. Some experimentation is required for locating the optimum position. The following are a few general guidelines:

- A) BASS RESPONSE--Play a record (or test signal) with repetitive bass. Try the speakers in several possible locations in the room. Begin moving the speakers forward or backward in increments of 6 to 12 inches. One position in the room should be noticeably better than others. Also experiment with your chair location. Positions close to a wall will often result in increased bass (often too much). See Figure 2.
- B) STEREO WIDTH AND IMAGING--Once you have located the best position for the speakers and your chair for bass performance, separate the speakers by 50% of the distance from your chair to the speakers. (For example, if your chair is 10 feet from the speakers, move the speakers 5 feet apart.) Now, move the speakers apart in increments of 3 or 4 inches at a time, listening carefully at each position. At some point you will start to hear two separate speakers instead of a “stage effect” (or continuous image). When this occurs, your speakers are too far apart: begin moving the speakers back in small increments until you notice a point at which you achieve one cohesive “sound stage.” For best results listen to speakers on axis with the listening position as shown in Figure 1 and 2.

Figure 1

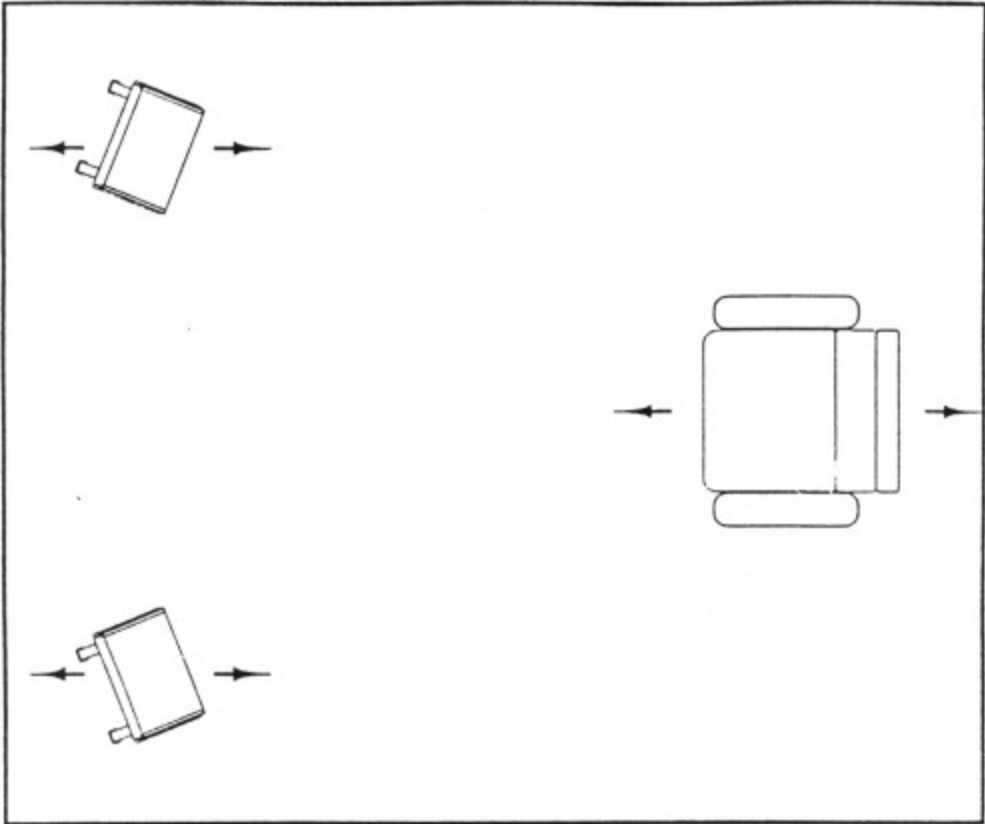
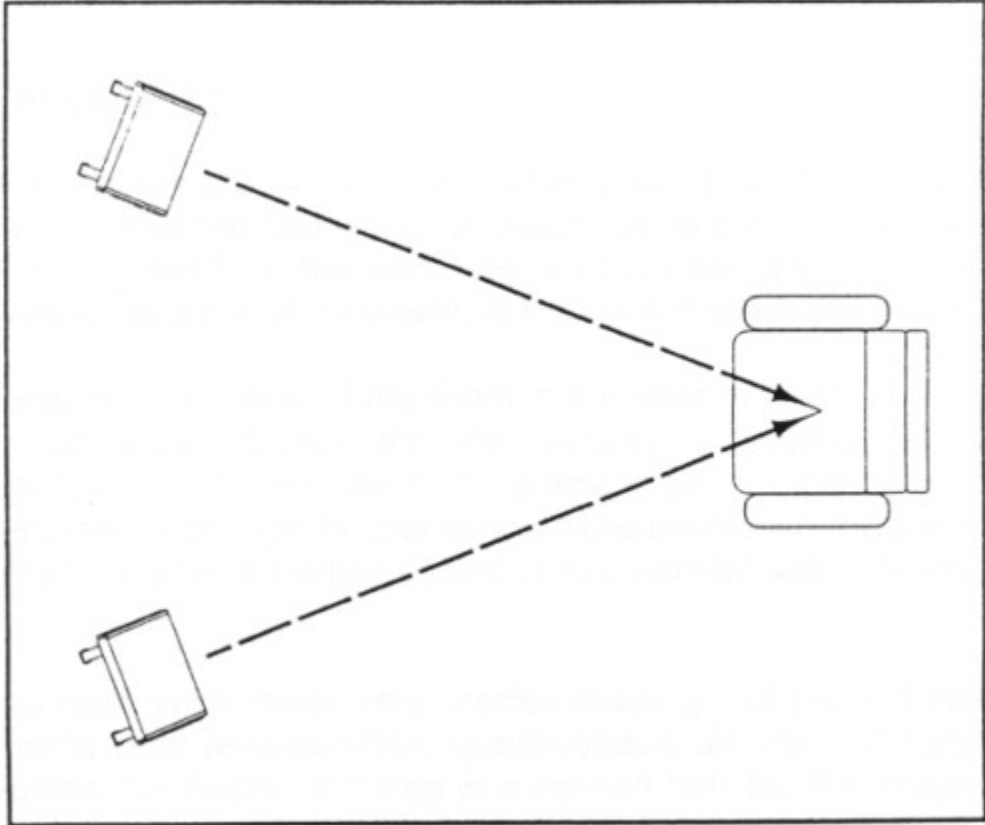

Figure 2



- C) LEFT/RIGHT--The MG12's are matched pairs and mirror-imaged. The serial number for each speaker in the pair is the same, except for a "1" or "2" following each serial number. As you face the front of the speakers, the speaker with the "1" after its serial number has the tweeter near the left edge, and the speaker with the "2" has the tweeter near the right edge.

To obtain correct phasing between the tweeter and bass of the MG12, the tweeters should be placed on the outside.

NOTE: Once you have located the ideal speaker position you should mark it. A small tack or piece of tape can be placed on the carpet so that your ideal listening spot can be easily relocated when the speakers (or chair) are moved for cleaning, etc. In the event that your ideal listening spot is inconvenient from the standpoint of the room layout and decor, simply slide the speakers wherever they look best. Experience has shown that the speakers can be placed close to a wall, and it will make little difference for FM or background listening.

The entire placement procedure may seem like a great deal of work, but is necessary in the setup of any high quality system. The time and effort expended should be necessary only once, and will repay the owner with countless hours of musical enjoyment.

8. ROOM ACOUSTICS

Magneplanars, like other bipolar speakers, usually sound best with a moderately reflective surface behind the speakers. In situations where the speakers must be placed as close as 2 feet from the back wall, a heavy damping material directly behind the speakers is advised; however, it should not cover the entire wall.

Damping material in other parts of the room is a matter of trial and error. A word of caution--when audiophiles discover the effectiveness of damping material, they sometimes overdo it (on the premise that if a little is good, more is better). Before you make a permanent change to your room, experiment with the positioning of the damping material. Usually a portion of one of two parallel walls should have some damping.

An overdamped room will provide very precise imaging, but you will have a reduced sense of ambience (less reverberation, spaciousness, air, etc.). An underdamped room may heighten the illusion of being in a concert hall, but the imaging will seem imprecise with all the instruments mixed together. Be aware that so-called hardness or overbright sound is usually the result of a room with hard surfaces (glass, hard paneling, etc.). Moderation is the word.

9. OPTIONAL TWEETER ATTENUATION

There are two principal reasons for needing to attenuate the Magneplanar Quasi Ribbon Tweeter:

- A) Recordings, typically in the “pop” or “rock” vein, often exhibit pronounced rise in the treble region.
- B) The Magneplanar Quasi Ribbon Tweeter is very efficient in its total “energy dispersion.” If the surround walls are exceptionally reflective, the overall perceived acoustical balance will be tipped towards a “hot” high end.

Attenuation is performed through insertion of a simple non-inductive resistor in series with the tweeter. See Figure 3.

Replace the left-hand jumper with the appropriate resistor to obtain the desired tweeter attenuation. The pair of 1 ohm non-inductive resistors will attenuate the tweeter 1-2dB. Other values are available from your Magneplanar dealer.

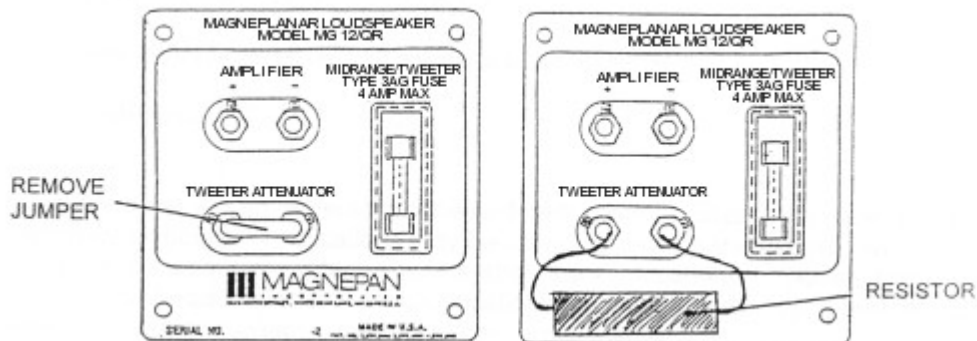

Figure 3

10. MAINTENANCE

- A. The hardwood frames can be cleaned with a slightly damp dust cloth.
- B. Light vacuuming of the grille cloth is possible.

11. SPECIFICATIONS*

<u>System Description:</u>	Two-Way Full Range Quasi Ribbon/Planar-Magnetic Dipole Radiator
<u>Frequency Response:</u>	45Hz - 22kHz \pm 3dB
<u>Recommended Power:</u>	100 to 250W @8 Ohms. For further information, see FAQ on web site at http://www.magneplan.com/faq.php#power
<u>Sensitivity:</u>	86dB @2.83V/1 Meter/500Hz
<u>Impedance:</u>	4 Ohms
<u>Bass-radiating area:</u>	8-1/2" X 43-1/2"
<u>Quasi Ribbon Tweeter Size:</u>	2" X 38"
<u>Crossover System:</u>	600Hz (Acoustical)
<u>Dimensions:</u>	17" W X 52-1/2" H X 1-1/2" D
<u>Warranty:</u>	Limited 3-Year to Original Owner
<u>Shipping Weight:</u>	63 Lbs

*Because there are no universally accepted methods for loudspeaker measurements, frequency response specifications may be stated by most manufacturers without reference to measurement techniques and/or specific locations in rooms. Magneplanar loudspeaker frequency response specifications are minimum average performance levels that may reasonably be expected in normal installations.

**New Magneplanar MG12/QR speakers will not display their full bass potential. After a month or two of use the bass response will lower a few cycles. At this point the response will stabilize and the speakers rated performance (or better) can be realized. While this 5Hz or more of lower bass response is important, the most important factors in obtaining good bass response from the MG12 speakers are room size and geometry, wall material, and speaker placement.